

- GENERAL NOTES** for all types of curb & gutter.
- Line and grade staked to T.C. - (top of curb) and F.C. - (face of curb) or lip of gutter.
 - Grade and alignment to be approved by the Public Works Dept.
 - The tolerance for finished curb, horizontal and vertical variance, is not to exceed 0.02' from line and grade as shown on plans.
 - Base will be 6" of 3/4 crushed gravel compacted to 95% max. dry density & to be placed in 6" lifts for all fill or backfill areas. No rock is needed under curb and gutter in cut areas.
 - Concrete will be 3000 psi.
 - Dummy joint at 10 ft. intervals, 3/16 inch deep, construction joints as directed by Engineer.
 - Name of contractor and year to be stamped on each end of work and at intervals of 100 feet. Bench mark bolt to be set in top of curb in radius when supplied and requested by the Public Works Dept.
 - The contractor may be required by the Public Works Dept. to mark stubouts and valves in the uncurbed concrete. The City will provide the necessary tools.
 - Inspection: The contractor or owner shall notify the Public Works Dept. for inspection of the base material after the forms are set, and the Public Works Dept. will be notified no less than 18 hours before placement of concrete for a "final" inspection.

Secure a permit for construction, before beginning construction in public right-of-way.

CITY OF LEWISTON STANDARD DRAWING

CURB & GUTTER CONSTRUCTION REQUIREMENTS

APPROVED	DATE	BY	EXPLANATION	REV. NO.
10-1-88	1-1-88	WJH	CHANGE	1

ST-1A

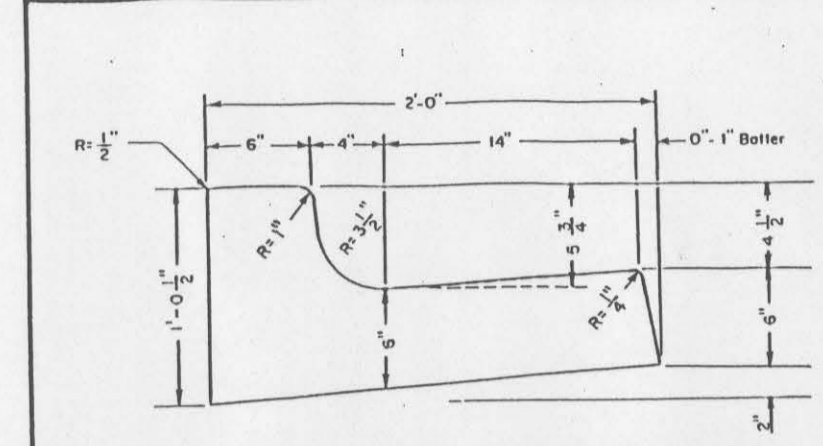

TYPE 1 HIGH BACK CURB & GUTTER

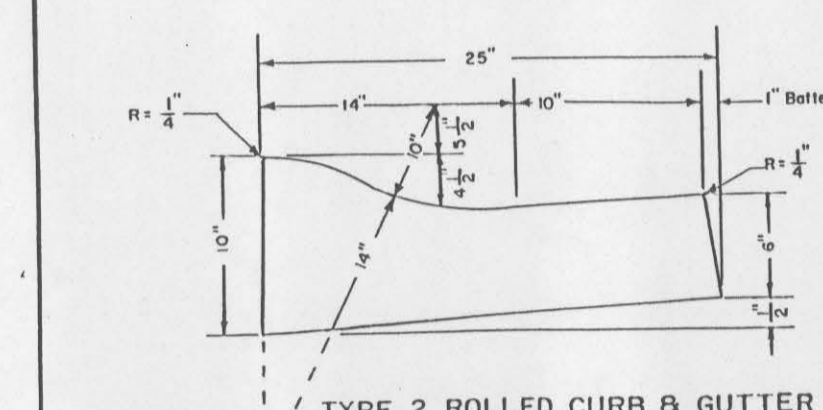

TYPE 2 ROLLED CURB & GUTTER

NOTE: Type 2 rolled curb and gutter shall only be installed with approval of Public Works Department.

CITY OF LEWISTON STANDARD DRAWING

CURB & GUTTER CONSTRUCTION REQUIREMENTS

APPROVED	DATE	BY	EXPLANATION	REV. NO.
10-1-88	1-1-88	WJH	CHANGE	1

ST-1B

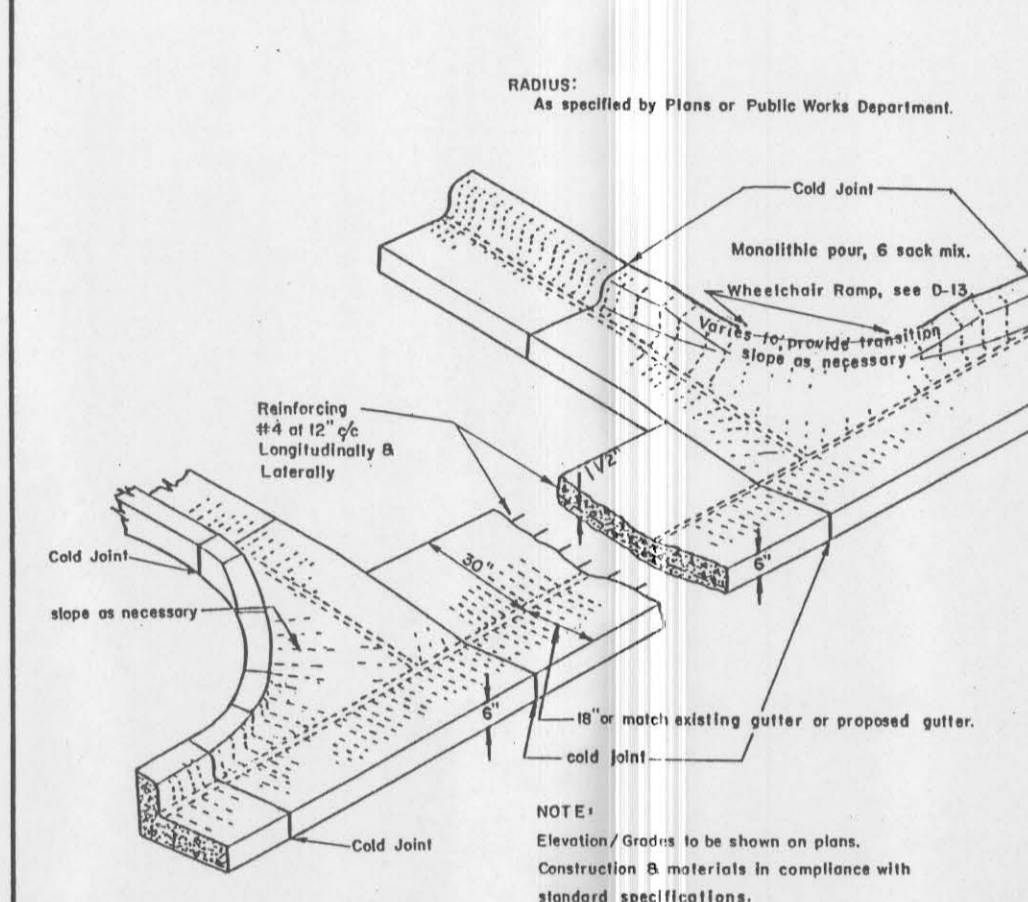

NOTE: Elevation/Grades to be shown on plans. Construction materials in compliance with standard specifications.

CITY OF LEWISTON STANDARD DRAWING

INTERSECTION VALLEY GUTTER

APPROVED	DATE	BY	EXPLANATION	REV. NO.
10-1-88	1-1-88	WJH	CHANGE	1

ST-2

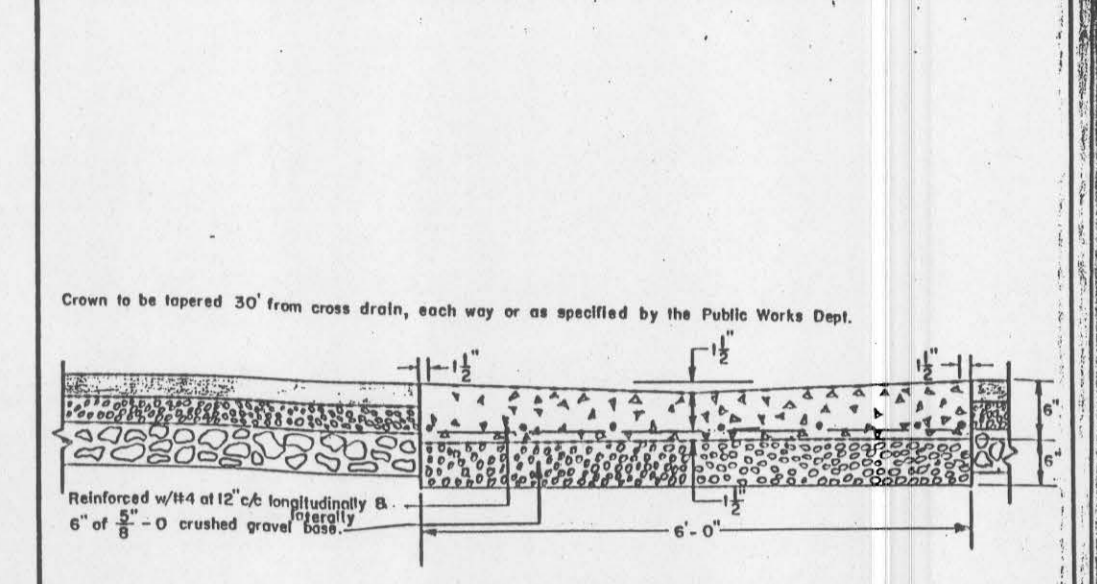

- Location and grade as shown on plans.
- Concrete to be 6 sack mix.

CITY OF LEWISTON STANDARD DRAWING

NON-INTERSECTION VALLEY GUTTER

APPROVED	DATE	BY	EXPLANATION	REV. NO.
10-1-88	1-1-88	WJH	CHANGE	1

ST-3

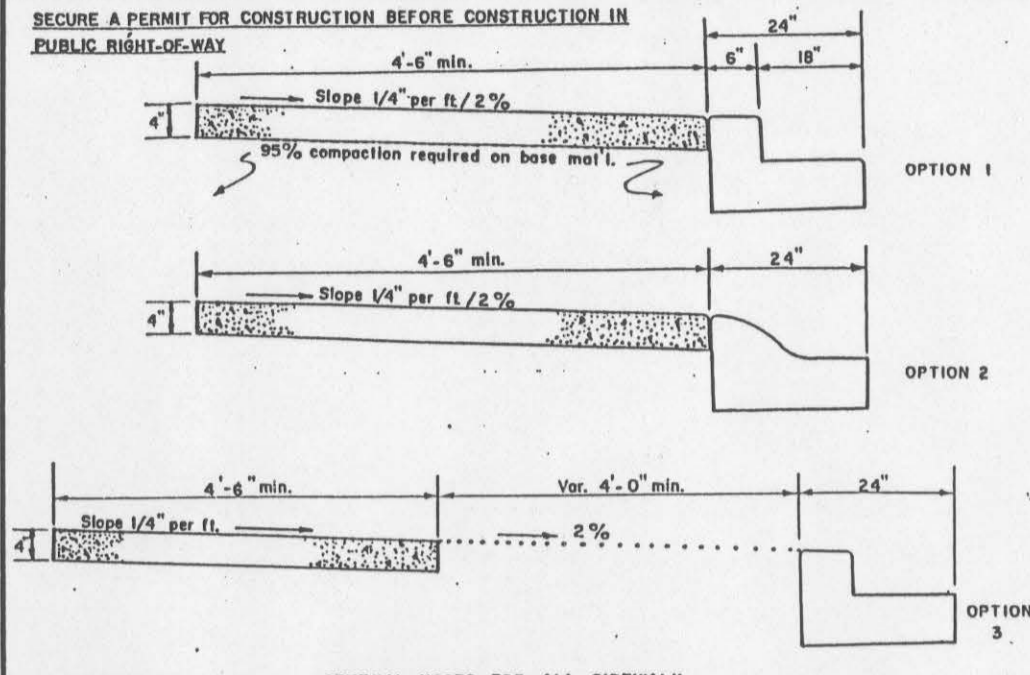

- GENERAL NOTES FOR ALL SIDEWALK**
- Line and grade staked to T.C. - top of sidewalk, B.S. - back of sidewalk.
 - Grade and alignment to be approved by the Public Works Department.
 - The tolerance for finished sidewalk, horizontal and vertical variance is not to exceed 0.02' from line and grade as shown on plans.
 - Base will be 6" of 3/4" crushed gravel compacted to 95% max. dry density and to be placed in 6" lifts for all fill or backfill areas. No rock is needed under sidewalk in cut areas.
 - Dummy joints shall be placed at 5' or 10' intervals, 3/16" deep.
 - Concrete will be 3000 psi.
 - Name of Contractor and year to be stamped on each end of work and at intervals of 100 ft.
 - The Contractor or Owner shall notify the Public Works Dept. for inspection of the base material after the forms are set and the Public Works Department will be notified no less than 18 hours before placement of concrete, for final inspection.
 - See ST-5 for Driveway Entrances.
 - Options 1 & 2 without planting strip with Public Works permission only.

CITY OF LEWISTON STANDARD DRAWING

CONCRETE SIDEWALK

APPROVED	DATE	BY	EXPLANATION	REV. NO.
10-1-88	1-1-88	WJH	CHANGE	1

ST-4

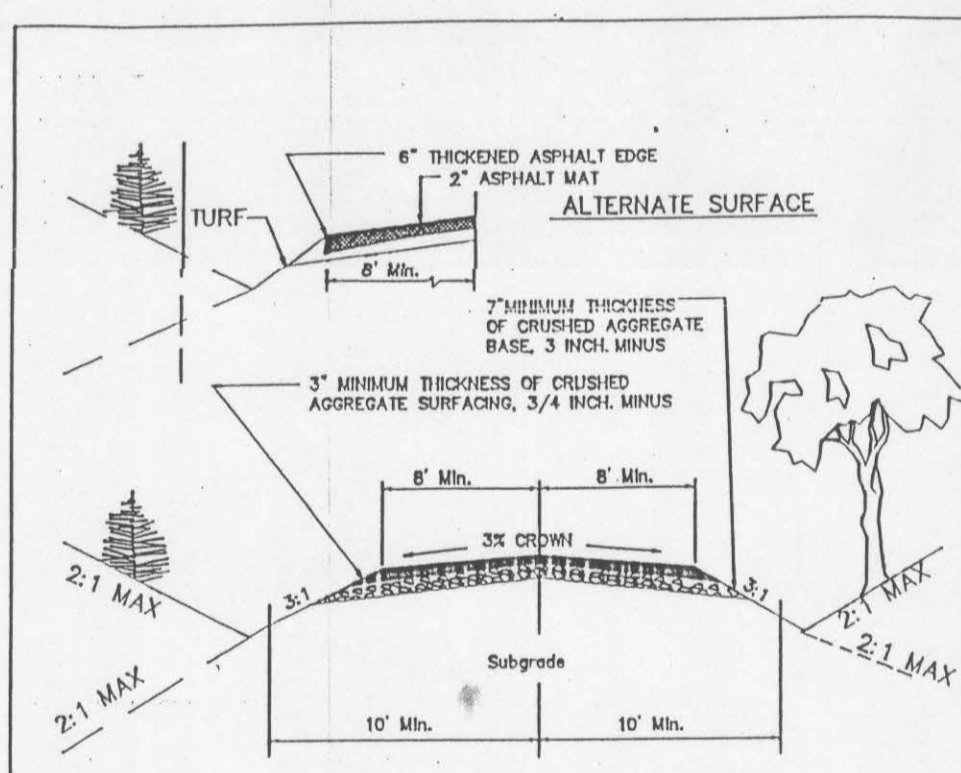

- Each layer of aggregate shall be compacted to 95% of the maximum density as determined by AASHTO 199-70, standard proctor test.
- 11% max. grade
 - 15'-20' corner radius
 - 175' centerline radius
 - Swale drainage

CITY OF LEWISTON STANDARD DRAWING

ALL-WEATHER AGGREGATE SURFACE FIRE APPARATUS ACCESS ROAD

APPROVED	DATE	BY	EXPLANATION	REV. NO.
10-1-88	1-1-88	WJH	CHANGE	1

PA-1

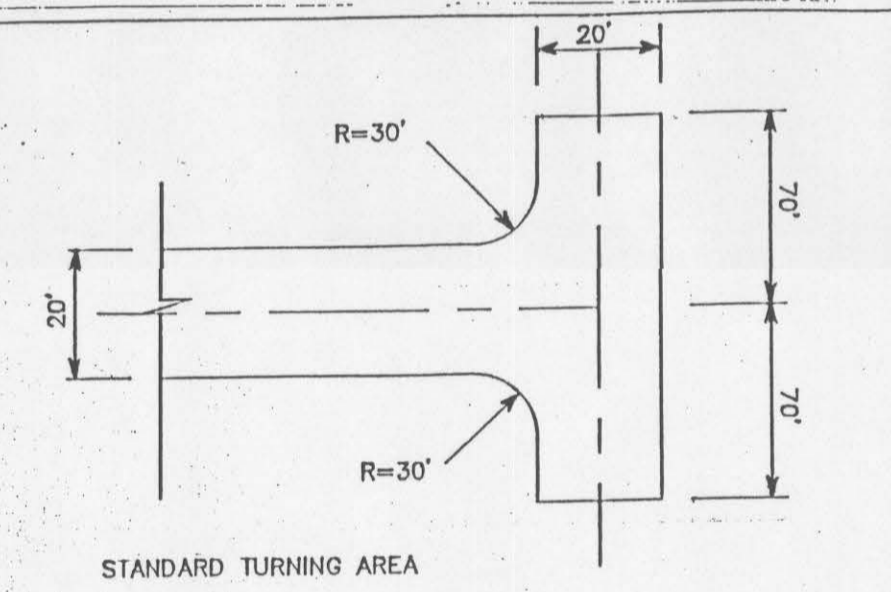

STANDARD TURNING AREA

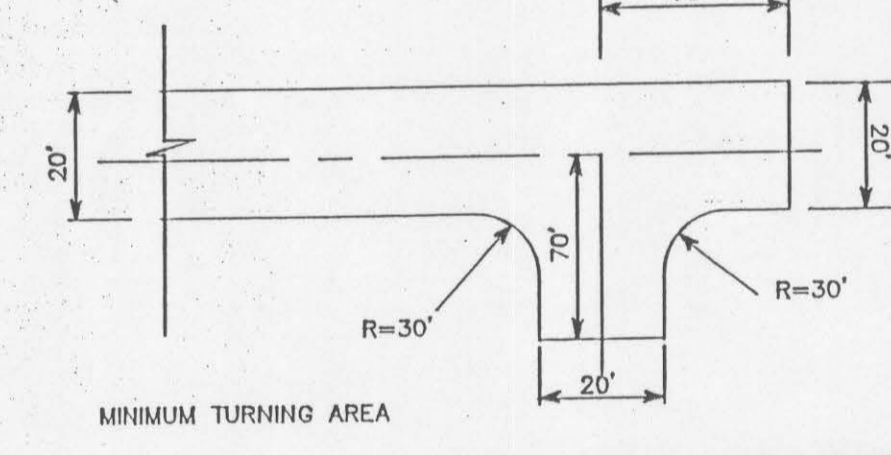

MINIMUM TURNING AREA

NOTE: 1. Residential use only.

CITY OF LEWISTON STANDARD DRAWING

ALTERNATE TURN AROUND

APPROVED	DATE	BY	EXPLANATION	REV. NO.
10-1-88	1-1-88	WJH	CHANGE	1

PA-2A

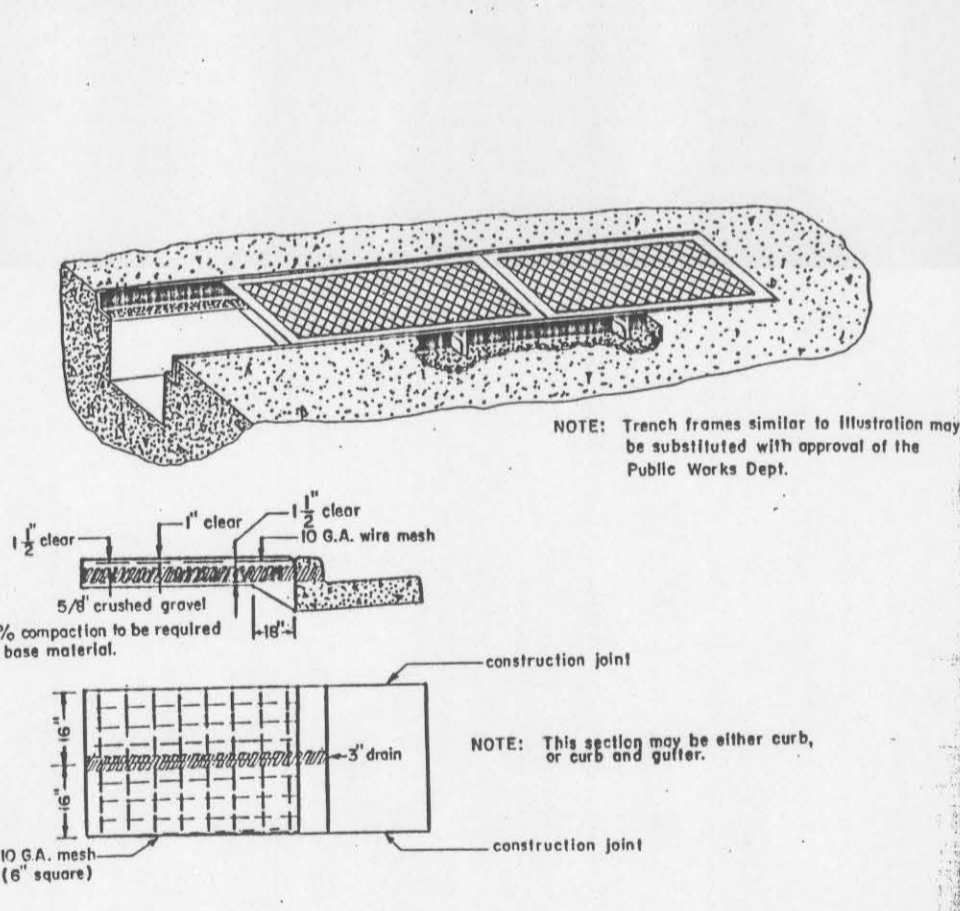

- GENERAL NOTES:**
- Construction joints shall be placed as shown or as directed by the Engineer.
 - Concrete shall be 3000 psi.
 - Permit and specifications to be obtained of Public Works Department.
 - No obstructions will be allowed in the sidewalk without permission of the Public Works Department.
 - Notify the Public Works Department no less than 18 hours prior to placing any concrete, for inspection purposes.

CITY OF LEWISTON STANDARD DRAWING

SIDEWALK DRAIN DETAILS

APPROVED	DATE	BY	EXPLANATION	REV. NO.
10-1-88	1-1-88	WJH	CHANGE	1

ST-1A

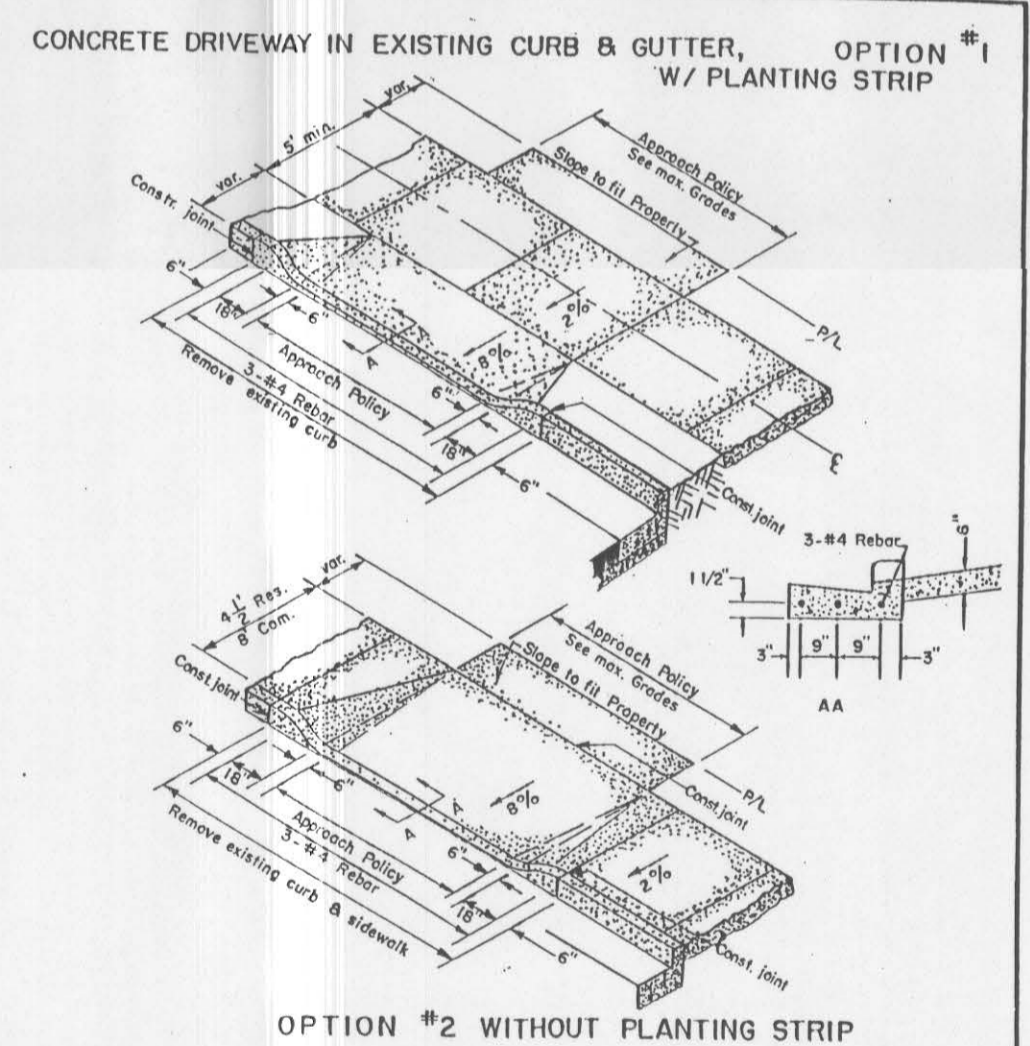

CONCRETE DRIVEWAY IN EXISTING CURB & GUTTER, OPTION #1 W/ PLANTING STRIP

- GENERAL NOTES:**
- Where driveway exceeds 12' width, a dummy joint shall be placed longitudinally at 10' max. intervals.
 - Clear and edge of joints. Traverse driveway joints, as shown or directed by Public Works Dept.
 - Construct 1" lip to driveway at gutterline.
 - Concrete shall be 3000 psi.
 - Thickness - 6" concrete.
 - Option 2 with Public Works permission only.

CITY OF LEWISTON STANDARD DRAWING

ALLEY AND DRIVEWAY ENTRANCE

APPROVED	DATE	BY	EXPLANATION	REV. NO.
10-1-88	1-1-88	WJH	CHANGE	1

ST-5

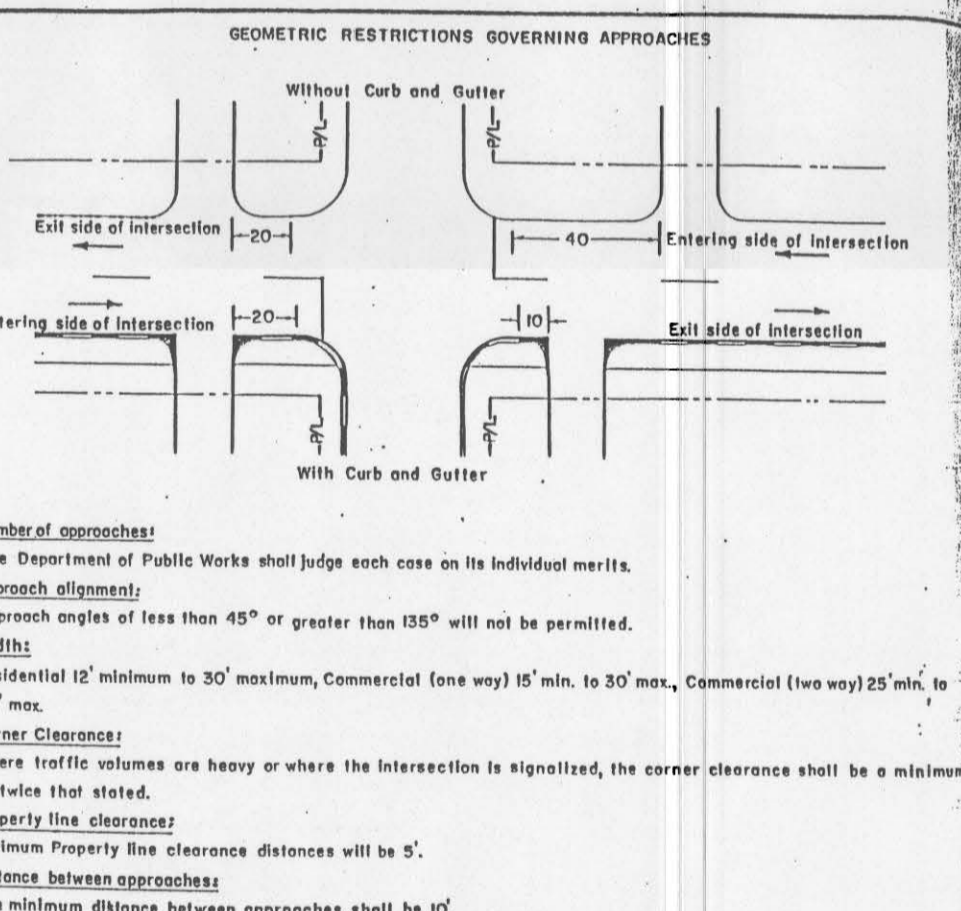

- Number of approaches:**
The Department of Public Works shall judge each case on its individual merits.
- Approach alignment:**
Approach angles of less than 45° or greater than 135° will not be permitted.
- Width:**
Residential 12' minimum to 30' maximum, Commercial (one way) 10' min. to 30' max., Commercial (two way) 25' min. to 40' max.
- Corner Clearance:**
Where traffic volumes are heavy or where the intersection is signalized, the corner clearance shall be a minimum of twice that stated.
- Property line clearance:**
Minimum Property line clearance distances will be 5'.
- Distance between approaches:**
The minimum distance between approaches shall be 10'.

CITY OF LEWISTON STANDARD DRAWING

STANDARD APPROACHES

APPROVED	DATE	BY	EXPLANATION	REV. NO.
10-1-88	1-1-88	WJH	CHANGE	1

ST-5A

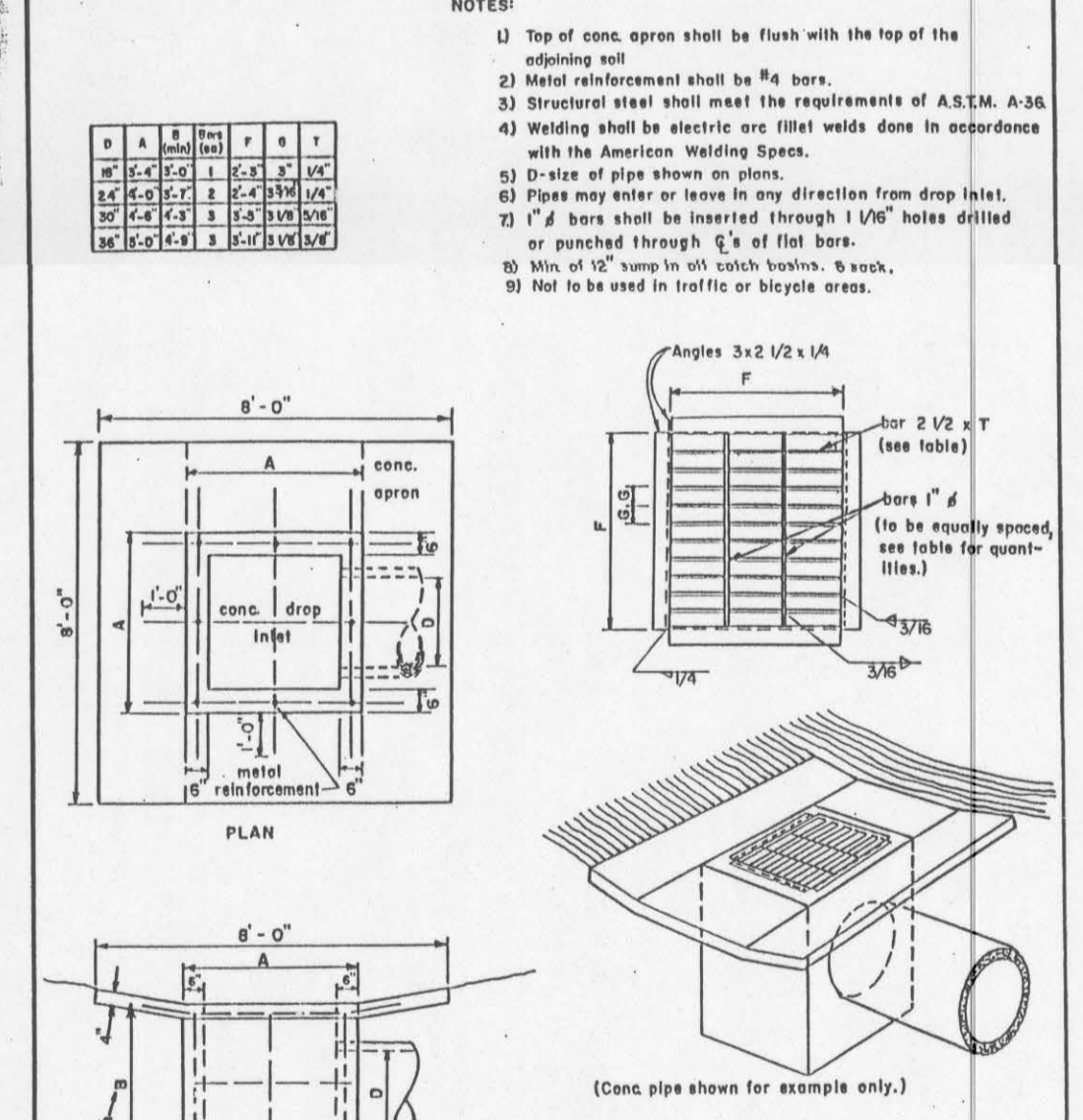

CITY OF LEWISTON STANDARD DRAWING

AREA DRAIN TYPE I

APPROVED	DATE	BY	EXPLANATION	REV. NO.
10-1-88	1-1-88	WJH	CHANGE	1

ST-6



These details do not apply to water line improvements.

Warren S. Wilts